

AX9045

DATASHEET



TECHNICAL DATA

Infeed dimensions:	900 x 450 mm
Drum diameter:	800 mm
Number of knives:	2
Drum speed:	1000 U/min
Sieve:	Hardox 400
Infeed pression:	3200 kg
Weight (Standard machine):	5200 kg
Power demand:	(min) 200 HP

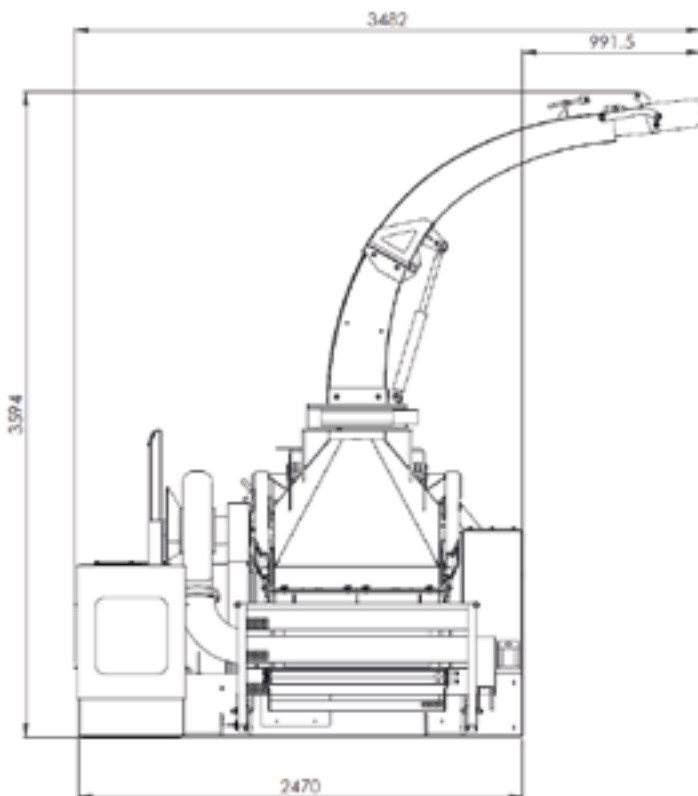
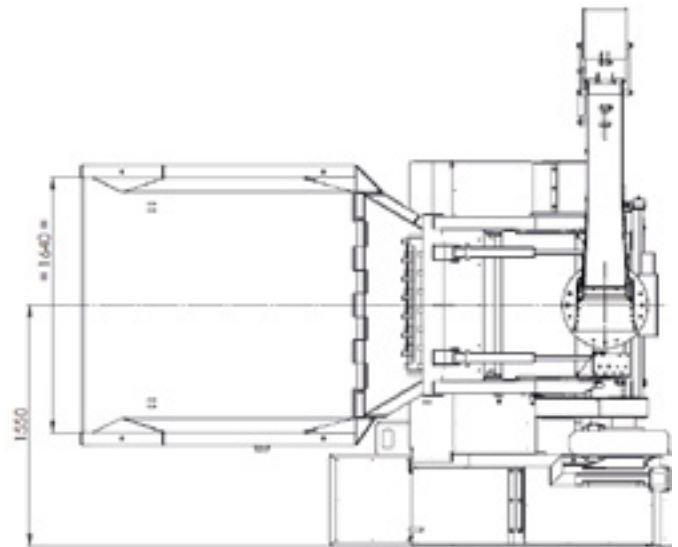

CALL FOR SUPPORT

+31 (0)315 - 69 54 70

TYPE AX9045

Compact chipper with closed drum;
Direct cut and throw without transporting augers and separate blower;
Infeed drums with inner laying hydraulic motors;
Own chassis;
Power supply by PTO and power belts.

Computer system: DD-ECS-CF system; Infeed speed variable, 0-60 m / min., adjustable from control unit; Separate control unit for hydraulic components (Chute, infeed table etc).	S
Non-Stress security	S
Air support	S
Chute – hydraulically controlled ø 30 cm	S
Chute extension	O
Infeed table – hydraulically controlled	S
Bio Hydraulic John Deere Bio Hydrau Gard	O
Camera	O
Undercarriage slow traffic with, High tipping container, ca. 22 m ³	O
Undercarriage slow traffic	O



ADDRESS De Stenenmaat 15, 7071 ED Uft (NL) MAILING ADDRESS P.O. Box 16, 7070 AA Uft (NL)

T +31 315 - 69 54 70 F +31 315 - 69 54 79 E info@henconforestry.com